

**Expert Advice. Great Value. Contact Us Today!**

**Call:** [203-647-9147](tel:203-647-9147) **Email:** [sales@haywardts.com](mailto:sales@haywardts.com)

**Website:** [www.haywardturnstiles.com](http://www.haywardturnstiles.com)

## Swing Gate LC150 ADA Motorized Swing Gate

**Affordable Value • Smart Passage Detection • Touchless Motorized Operation**



**SwingGate LC150 Motorized**  
(36" ADA opening)

### **Affordable ADA Compliance:**

The LC150 ADA Motorized cabinet style gate is an affordable and durable entry control solution. Standard features include heavy wall cabinet construction, touchless motorized operation, and a powder coat finish. Its rugged, no-frills design is constructed for use in high traffic areas and performs well under heavy usage.

This touchless motorized swing gate features a smart motor that drives the swinging barrier that can be optionally coupled with our optical rail detection system to provide a comprehensive, one-way enforcement system often used for theft mitigation at retail environments like grocery stores and convenience stores.

The LC150 ADA gate matches our LC100 waist high turnstile both in construction and aesthetics. This makes the LC150 ADA a great choice when you need to pair an ADA gate with your LC100 waist high turnstile array. Coupled together, the LC150 ADA and the LC100 waist high turnstile provide a comprehensive, ADA compliant entry solution.



### **Optional Sensor Rail System**

*Available to detect oncoming traffic and open the gate automatically. Great for one-way traffic enforcement in retail environments for theft prevention*

### **About Hayward Turnstiles:**

Hayward Turnstiles is a family owned manufacturer and distributor of turnstiles and security gates in Connecticut with over 50 years of precision manufacturing success.

Here at Hayward, customer service and a stress-free ordering environment are our primary goals. The members of our sales team act as your personal access control specialists. They take the time to learn about your specific project needs to ensure that you are matched with the products that best fit your job requirements.

To aid in your decision making process, we offer access control advice, design assistance, same-day quotations, and can even coordinate installation by putting you in contact with an installer from our national network of certified partner installers. We go the extra mile so you don't have to.

### **Need Installation?**

Our Hayward Turnstiles access control specialists can coordinate installation with someone from our nationwide database of certified partner installers. Our partner installers are willing to provide you with an entire turn-key quote where they will handle purchasing, delivery, installation, and integration for you.

**Applications:**

The LC150 ADA Motorized is a great solution for providing hands-free handicap access. This product mates usability with cost consciousness, allowing you to provide touchless handicap access without breaking the bank. Including our optional sensor rail system expands the LC150 use case further, allowing you to use it for one-way traffic enforcement. The sensor rails detect when people are approaching the gate and automatically opens the gate to let them through while cross beam cabinet sensors ensure the gates do not prematurely close on people. This setup is great for retail entrances; allowing people to enter the store but not sneak out the entrance with stolen goods.

**Specifications:**

- 36" ADA clear opening single width (standard sized)
- Motorized passage in either one-way or two-way swing
- Hardened tool steel locking bars, cam, and roller assemblies
- Permanently lubricated bearings
- Powder coat finish walls with 304 stainless top
- Side walls are heavy 7-gauge carbon steel
- Arms are 12 gauge stainless steel

**Electronic Specifications:**

- Input voltage: 100-240 VAC | Operating voltage: 24 VDC
- Input current: 2.15-1.13A | Output current: 10 Max
- Frequency: 50/60 Hz

**Options:**

- Sensor Rail System to enforce one-way traffic, deter premature gate closure, and more
- Daylight visible indicator lights
- Bi-directional key overrides
- Variable arm lengths up to 40"
- Signage holder
- Wave to open switch
- Additional options available upon request

**Warranty:**

Units are warranted against defects in materials and workmanship for a period of one year from date of delivery. See warranty information for specific details.

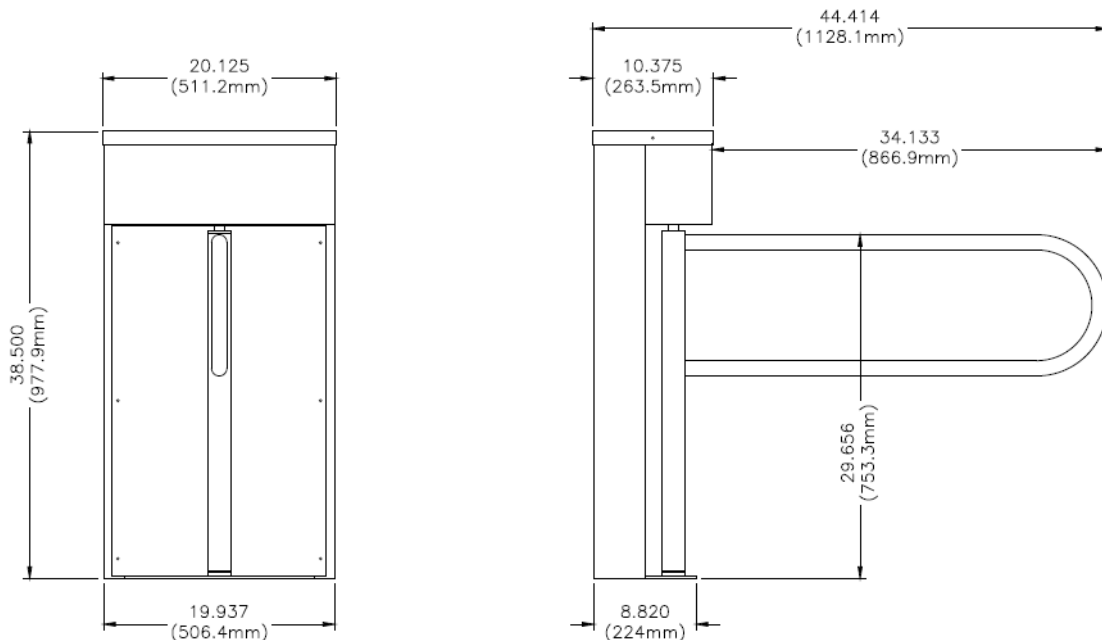

ALL DIMENSIONS ARE APPROXIMATE  
 DIMENSIONS IN INCHES (mm)  
 DIMENSIONS SUBJECT TO CHANGE WITHOUT NOTICE