

Expert Advice. Great Value. Contact Us Today!

Call: [203-647-9147](tel:203-647-9147) Email: [sales@haywardts.com](mailto:sales@haywardts.com)  
Website: [www.haywardturnstiles.com](http://www.haywardturnstiles.com)

## HT70 High Security Portal

- Modern Aluminum Design
- Floor-to-Ceiling Security
- Tamper Resistant

- Ultrasonic Wrong-Way Detection
- Clear Sidewalls for Open Look
- Solid Roof Canopy with Lighting

*Revolving door look...turnstile functionality.*



### HT70 Standard Passage

*(Frameless Clear Glass Rotating Door Panels)*

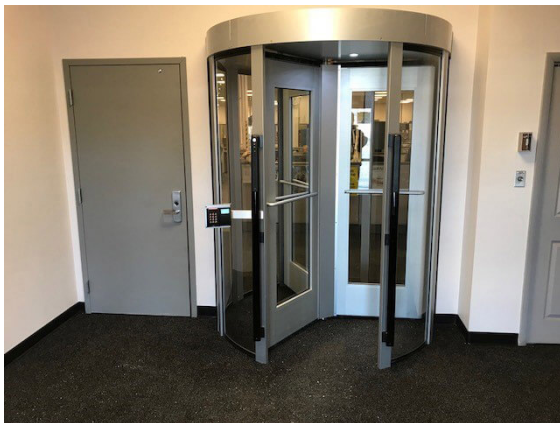

### HT70 Installed

*(Optical Piggyback detection and card reader mounting plates shown)*

#### **Sophisticated Security Portal:**

The HT70 is an advanced and stylish 3-vane high security turnstile portal. This entry solution is the perfect cross between a full height turnstile and a revolving security portal. It features a sophisticated ultrasonic sensor to detect and deter wrong-way passage. With its enclosed design, the HT70 also reduces wind and noise transfer between connected areas, allowing you to seamlessly mate office spaces with work areas.

The HT70 performs the same way as a conventional full height turnstile but with a less imposing look thanks to its clear sidewalls and clear barriers. This model is available in clear anodized or dark bronze anodized with a plethora of additional options to choose from like optical piggybacking detection, metal detection, bullet-proof materials, cold weather packages, and more.

#### **About Hayward Turnstiles:**

Hayward Turnstiles is a family owned manufacturer and distributor of turnstiles and security gates in Connecticut with over 50 years of precision manufacturing success.

Here at Hayward, customer service and a stress-free ordering environment are our primary goals. The members of our sales team act as your personal access control specialists. They take the time to learn about your specific project needs to ensure that you are matched with the products that best fit your job requirements.

To aid in your decision making process, we offer access control advice, design assistance, same-day quotations, and can even coordinate installation by putting you in contact with an installer from our national network of certified partner installers. We go the extra mile so you don't have to.

#### **Need Installation?**

Our Hayward Turnstiles access control specialists can coordinate installation with someone from our nationwide database of certified partner installers. Our partner installers are willing to provide you with an entire turn-key quote where they will handle everything from purchasing to delivery, installation, and integration for you.

## HT70 Specifications

### Applications:

The HT70 is perfect for high security engagements where you need to guard against pass back attempts or other security threats. It is also great for when you need to separate different areas of a facility like separating between the production and office portions of a building. The HT70 helps reduce wind and noise transfer, provides high levels of security, and checks credentials, all with an open look and feel.

### Product Finish:

Clear anodized. Other finishes upon request.

### Design & Construction:

- Designed for secure operations with visual appeal
- Anodized aluminum frame with clear lifetime finish
- Heavy gauge internal steel framing (mainframe & canopy)
- Frameless Clear Glass Rotating Door Panels
- Exterior Clear Lexan Sidewalls
- Clear tempered glass (doors)
- Heavy gauge steel inserts (mainframe & canopy)
- Stainless fasteners
- Hardened tool steel locking bars, cams and roller assemblies
- Permanently lubricated sealed bearings

### Turnstile Operation:

- Ultrasonic barrier detects incorrect entry side with audible

alert and reverses turnstile for exit

- Choice of right or left-handed direction
- Self-centering mechanism with hydraulic shock suppression
- Choice of fail safe (unlock on power loss) or fail secure (lock on power loss)
- Easily integrates to access control & fire safety systems
- Interfaces with card readers, biometrics, wireless remotes and push buttons.

### Options:

- Card reader mounting plates
- Electronic resettable counter with LCD display and 7-year lithium battery
- Low voltage canopy lighting
- Optical Piggybacking Detection
- Metal detection
- Custom decorative aluminum top
- Additional options upon request.

### Electrical Specifications:

Power supply input 100-240VAC (.7 amp) 50/60hz output 24VDC (1.1 amp) UL Approved

### Warranty:

Units are warranted against defects in materials and workmanship for one year.



## HT70 Dimensions

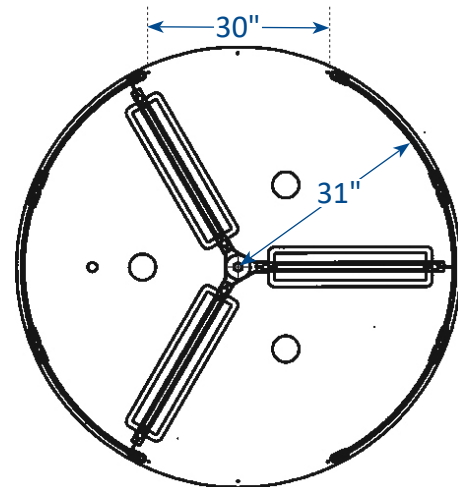
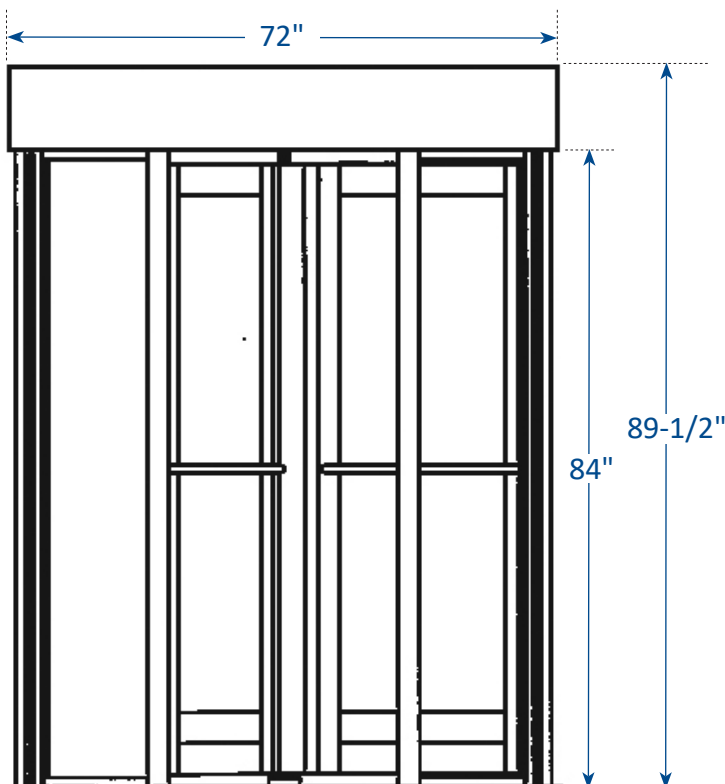

**Expert Advice. Great Value. Contact Us Today!**

Call: [203-647-9147](tel:203-647-9147) Email: [sales@haywardts.com](mailto:sales@haywardts.com)

Website: [www.haywardturnstiles.com](http://www.haywardturnstiles.com)