



Expert Advice. Great Value. Contact Us Today!

Call: [203-647-9147](tel:203-647-9147) **Email:** sales@haywardts.com

Website: www.haywardturnstiles.com

**SecureTurn HT431T Tandem
 Standard Passage**

**Full height for maximum security.
 Heavy-duty construction lasts a lifetime.**

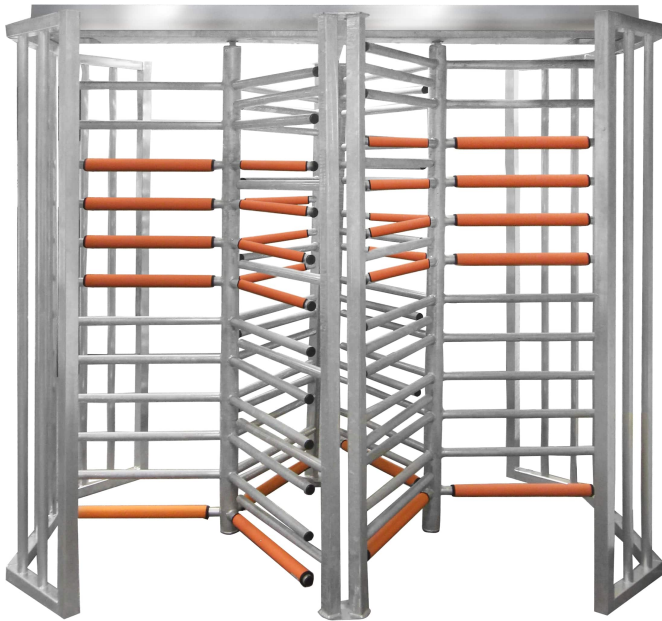

SecureTurn HT431T (Standard Passage)

*Shown with optional Safety Sleeve Bulk Pack Tandem (30 sleeves).
 Color choice of Safety Orange or Steel Gray.*

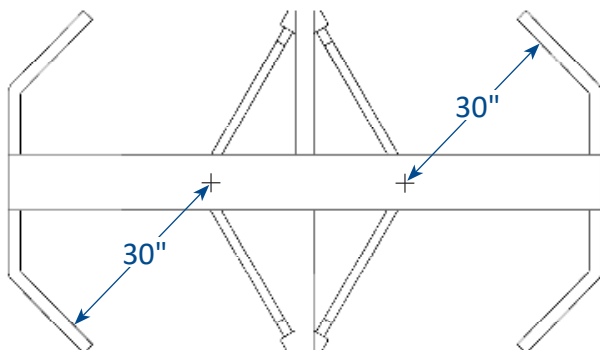

*See back for detailed
 dimensions and specifications.*

Space-Saving Tandem Turnstile:

The SecureTurn HT431T tandem full height turnstile is our most popular tandem full height turnstile because it is extremely dependable, easy to install, and made right here in our USA-based manufacturing facility. The HT431T features tamper proof construction and floor to ceiling security. This full height turnstile easily integrates with virtually any access control hardware or software via a momentary dry contact, making it the perfect access control solution for any application. Each HT431T comes with 6 free full height turnstile Safety Sleeves in Safety Orange.

Materials and finishes available in:

- Hot Dip Galvanized Steel
- Powder Coat over Steel

Other single passage models in this series:

- SecureTurn HT431 Standard Passage 31"
- SecureTurn HT440 Wide Passage 40"
- SecureTurn HT448 Extra Wide Passage 48"

About Hayward Turnstiles:

Hayward Turnstiles is a family owned manufacturer and distributor of turnstiles and security gates in Connecticut with over 50 years of precision manufacturing success.

Here at Hayward, customer service and a stress-free ordering environment are our primary goals. The members of our sales team act as your personal access control specialists. They take the time to learn about your specific project needs to ensure that you are matched with the products that best fit your job requirements.

To aid in your decision making process, we offer access control advice, design assistance, same-day quotations, and can even coordinate installation by putting you in contact with an installer from our national network of certified partner installers. We go the extra mile so you don't have to.

Need Installation?

Our Hayward Turnstiles access control specialists can coordinate installation with someone from our nationwide database of certified partner installers. Our partner installers are willing to provide you with an entire turn-key quote where they will handle everything from purchasing to delivery, installation, and integration for you.

HT431T Specifications

Applications:

Our SecureTurn HT431T standard passage is the perfect fit for when multiple lanes of floor to ceiling security is required. It can be integrated with virtually all access control readers and software, making it the perfect high-security entrance device or perimeter security solution. HT431Ts are often integrated into fence lines and are often used outdoors to increase security and control access into and out of facilities. Our HT431T matches our HTG and HTG-M full height ADA gates in both size and appearance, making them the perfect pair for when handicap access is required.

Product Features:

Materials and finishes in your choice of:

- Hot dipped galvanized steel
- Powder Coat over steel

Design & Construction:

- Tamper proof, rugged design
- Configurable for right or left handed entry direction
- Fully welded exterior components
- Heavy-duty lifetime construction
- 6 free safety sleeves with every HT431T purchased

Turnstile Operation:

- Self centering mechanism with hydraulic shock suppression

- Permanently lubricated bearings
- Clockwise, counter clockwise, or bidirectional passage

Options:

- Electronic locking module featuring heavy-duty 24 VDC solenoids that can integrate with virtually all access control software and hardware via a momentary dry contact
- Choice of fail safe (*unlock on power loss*) or fail secure (*lock on power loss*) for electric units only
- Card reader mounting plates (*electric units only*)
- Key override for electric or manual units (*both directions*)
- Red and green indicator lights (*electric units only*)
- Safety Sleeves (*Safety Orange or Steel Gray*)
- Heavy-duty lock bar (*included HD padlock and key*)
- Additional options available upon request

Electrical Specifications:

Power supply input 100-240VAC (.7 amp) 50/60hz output 24VDC (1.1 amp) All components UL recognized

Warranty:

Units are warranted against defects in materials and workmanship for a period of one year from date of delivery. See warranty information for specific details.



HT431T Dimensions

