

Expert Advice. Great Value. Contact Us Today!

Call: [203-647-9147](tel:203-647-9147) Email: sales@haywardts.com

Website: www.haywardturnstiles.com

**EZ Lane SL1000 Swing Glass
Enhanced Barrier Security
Wear Resistant Polyurethane Body**

- **Swing Glass Barrier**
- **Wear Resistant Polyurethane Body**
- **Tailgate Detection**
- **Bi-Directional**
- **Simple Programming**



EZ Lane SL1000

(24" Standard opening up to 36" ADA opening)

Free-flowing, contactless passage meets elegant design and sophistication with the Hayward Turnstiles EZ Lane SL1000 Swing Glass Optical Turnstile. Featuring a wear-resistant Polyurethane Body, optional Ethernet connectivity, and an onboard configuration display, the SL1000 is truly on the forefront of access control innovation and user friendliness.

The SL1000 enhances user experience in both design and functionality. Unlike other optical turnstile options, the SL1000 does not require you to plug in a laptop or tablet to access all functions, parameters, and information. Simply navigate the onboard display to control lanes, gather information, and much more. Each SL1000 integrates seamlessly into building control systems via their available Ethernet interface capabilities (optional), allowing you to easily integrate with existing programs at your facility.

The EZ Lane SL1000 is offered with swinging glass barriers in a variety of heights to appeal to varying levels of security requirements. The SL1000 also provides bi-directional access with passage openings of 1 second or less for high traffic installations. This turnstile uses optical beams to prevent tailgating and can be configured for ADA compliance.



EZ Lane SL1000 High Glass Option 70"

**Narrow Profile Cabinets with Color
Choices to Match any Decor**

Cabinet styles available in multiple colors to enhance the aesthetic appeal of any location. Choose optional logo etching of glass panels for unparalleled customization capabilities.



EZ Lane SL1000 Color Options Available

Need Installation?

Our Hayward Turnstiles access control specialists can coordinate installation with someone from our nationwide database of certified partner installers. Our partner installers are willing to provide you with an entire turn-key quote where they will handle purchasing, delivery, installation, and integration for you.

Applications:

The EZ Lane SL1000 is an aesthetically pleasing swing glass optical turnstile that offers an enhanced level of security with a highly wear resistant cabinet. The glass barriers are available in a variety of heights and lane widths depending upon your security needs.

STANDARD FEATURES

Quick and smooth motorized swing glass for bi-directional operation and fast passage (barrier opening of 1 sec. or less).

Optical Detection:

Sensors linked to CPU for high accuracy detection of pedestrians

Throughput/Capacity:

Barrier opening times of 1 second or less for rapid user throughput

Card Stacking:

- Lane remains open while authorizing multiple credentials
- Increases throughput during busy periods

Easy Configuration:

- Onboard configuration screen and buttons allow you to make changes on the fly without connecting an external device

Alerts (Visible LED & Audible):

- Access Allowed: Green light and confirmation tone
- Access Declined: Red light and rejection tones

Tailgate Detection:

- Assures that only one person enters for each authorized credential
- Prevents "Piggybacking" by unauthorized persons

Polyurethane Cabinet:

- Highly resistant to forceful impacts and to harsh chemicals
- Available in multiple colors

Floor Illumination:

- For aesthetic purposes and lane indication

Frame Illumination:

- Frame edge LED in red/green with separate control of entry and exit side

- For either permanent illumination or indication of lane status

Gate End Display:

- Indicator light located above reader mounting area for signaling passage direction and lane status with red and green LED lights

Integration:

- Easily integrates to access control and fire safety systems
- Optional Ethernet interface for simple integration with building controls
- Internal reader mounting area for proximity readers
- Factory installation available - End user supplied reader

Power Failure/Emergency Mode:

- Barrier will swing free at power failure/emergency
- Barrier auto-resets when power is restored

Quality Control:

Every unit is inspected, tested, and certified before shipment

OPTIONS

Ethernet Module

- Integrate with current programs at your facility
- Parameterization and signal processing via local network or web

Lane Mounting Plat orm (for above floor wiring):

- Cabinet is mounted on pedestal base to conceal wiring
- Walk over conduit for quick installation (no-drilling)

Panel Etching Options

Personalized 3/8" Polycarbonate Panel Etching (e.g. Company Logo)- Glass Cannot be Etched, Must Use Polycarbonate Instead

Cabinet Color

- More than 20 color tones available

POWER REQUIREMENTS

Input: 110-240 VAC, 50/60Hz

Power Consumption: Maximum 45 W

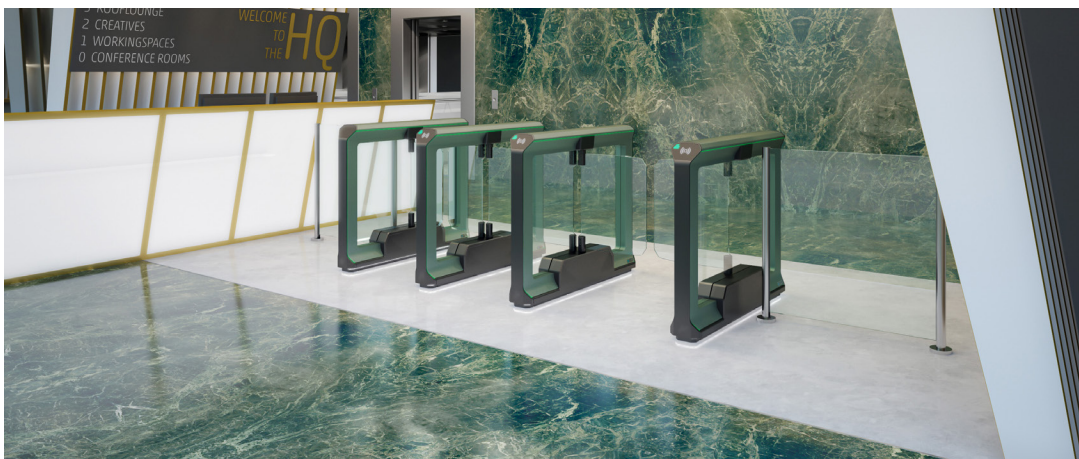

EZ Lane SL1000 Low Barrier Dimensions

(24" Standard opening up to 38" ADA opening, custom lane widths available)

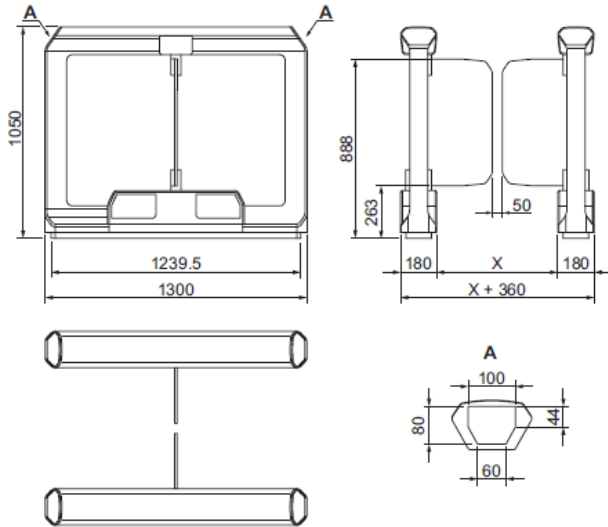

Dimensions SL1000 with swing barrier at standard height (dimensions in mm), X corresponds to ordered passage width

A: Installation space for reader without the option of the passage direction display, installation depth 40 mm

EZ Lane SL1000 High Barrier Dimensions

(24" Standard opening up to 38" ADA opening, custom lane widths available)

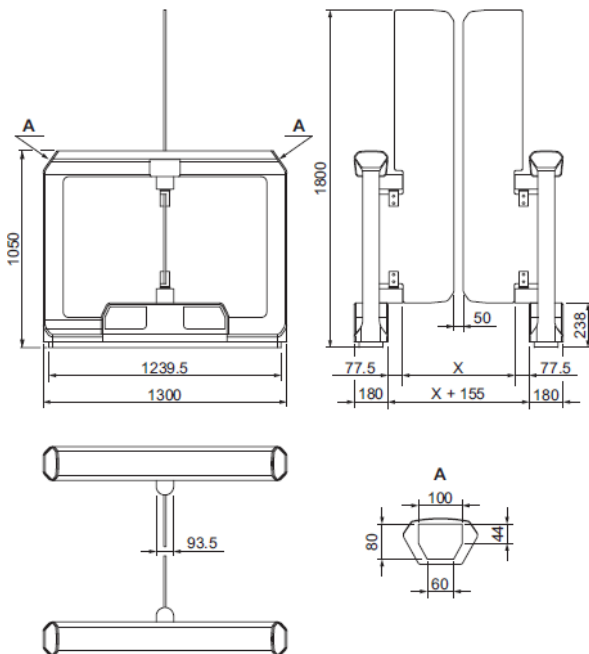

Dimensions SL1000 with swing barrier in high version (dimensions in mm), X corresponds to the ordered passage width

A: Installation space for reader without the option of the passage direction display, installation depth 40 mm