



Expert Advice. Great Value. Contact Us Today!

Call: [203-647-9147](tel:203-647-9147) **Email:** sales@haywardts.com

Website: www.haywardturnstiles.com

**SecureTurn HT431
 Standard Passage**

**Full height for maximum security.
 Heavy-duty construction lasts a lifetime.**

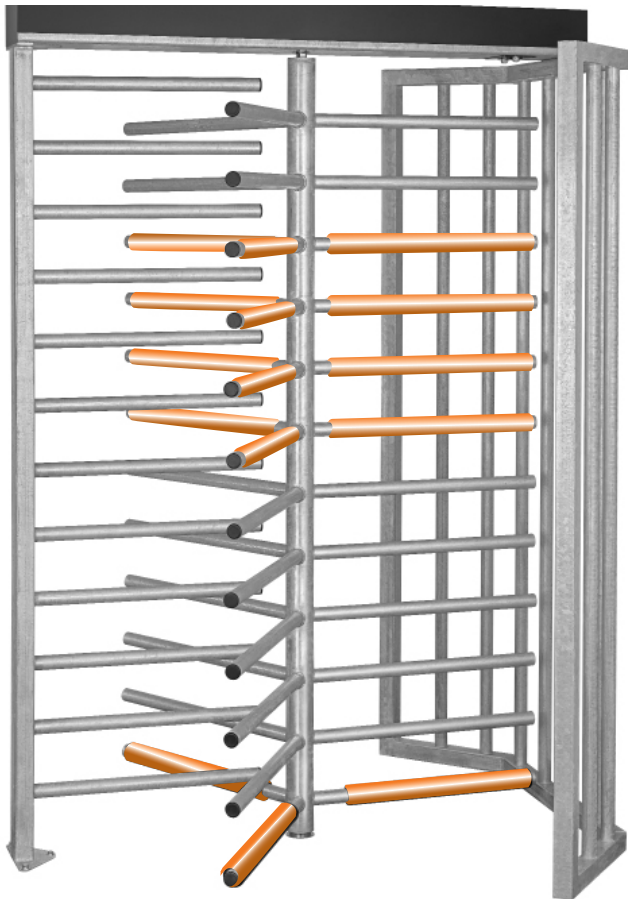

SecureTurn HT431 Standard Passage

Shown with optional Safety Sleeve Bulk Pack (15 sleeves).

Color choice of Safety Orange or Steel Gray.

Flagship Full Height Turnstile:

The SecureTurn HT431 standard passage is our most popular full height turnstile because it is extremely dependable, easy to install, and made right here in our USA-based manufacturing facility. The HT431 features tamper proof construction and floor to ceiling security. This full height turnstile easily integrates with virtually any access control hardware or software.

Materials and finishes available in:

- Hot Dip Galvanized Steel
- Powder Coat over Steel

Optional Padded Safety Sleeves:

Hayward Turnstiles Safety Sleeves are the perfect addition to your full height turnstile. Simply zip them onto your turnstile's arms to prevent injuries, enhance usability, and insulate turnstile arms from extreme temperatures that may be harmful to your turnstile's users.

Other single passage models in this series:

SecureTurn HT440 Wide Passage 40"

SecureTurn HT448 Extra Wide Passage 48"

Double passage models in this series:

SecureTurn HT431T tandem size for standard passage consists of (2) SecureTurn HT431 in a space saving layout.

Need Installation?

Our Hayward Turnstiles access control specialists can coordinate installation with someone from our nationwide database of certified partner installers. Our partner installers are willing to provide you with an entire turn-key quote where they will handle everything from purchasing to delivery, installation, and integration for you.

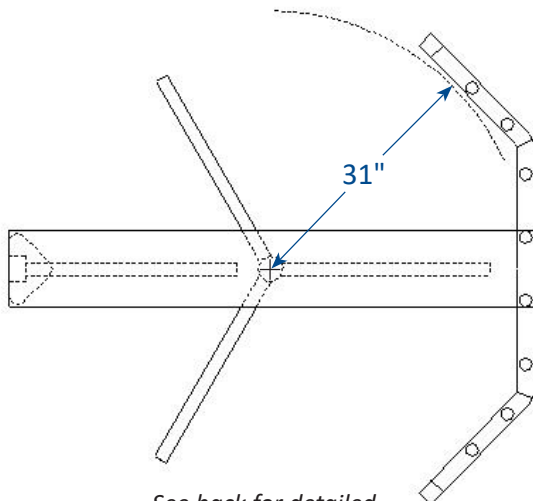

See back for detailed dimensions and specifications.

***SAFETY SLEEVE SAVINGS BONUS**

Your choice of with any full height turnstile order:

- Heel Pack (3 sleeves) - ~~\$149.95~~ (Save \$149.95)...now FREE* or
 - Bulk Pack (15 sleeves) - ~~\$749.95~~ (Save 33%)...now \$499.95* or
 - Total Pack (36 sleeves) - ~~\$1,799.95~~ (Save 33%)...now \$1,195.95*
- Additional sleeves \$49.95 each...Call 203-647-9144 for details.

HT431 Specifications

Applications:

Our SecureTurn HT431 standard passage fits perfect for when floor to ceiling security is required. It can be integrated with virtually all access control readers and software, making it the perfect high-security entrance device or perimeter security solution. HT431s are often integrated into fence lines and are often used outdoors to increase security and control access into and out of facilities. Our HT431 matches our HTG and HTG-M full height ADA gates in both size and appearance, making them the perfect pair for when handicap access is required.

Product Features:

Materials and finishes in your choice of:

- Hot dipped galvanized steel
- Powder Coat over steel (custom colors available)

Design & Construction:

- Tamper proof, rugged design
- Configurable for right or left handed entry direction
- Fully welded exterior components
- Heavy-duty lifetime construction
- 3 free safety sleeves with every HT431 purchased

Turnstile Operation:

- Self centering mechanism with hydraulic shock suppression
- Permanently lubricated bearings

- Clockwise, counter clockwise, or bidirectional passage

Options:

- Electronic locking module featuring heavy-duty 24 VDC solenoids that can integrate with virtually all access control software and hardware via a momentary dry contact
- Choice of fail safe (*unlock on power loss*) or fail secure (*lock on power loss*) for electric units only
- Card reader mounting plates (*electric units only*)
- Key override for electric or manual units (*both directions*)
- Red and green indicator lights (*electric units only*)
- Safety Sleeves (*Safety Orange or Steel Gray*)
- Heavy-duty lock bar (*included HD padlock and key*)
- Additional options available upon request

Electrical Specifications:

Power supply input 100-240VAC (.7 amp) 50/60hz output 24VDC (1.1 amp) All components UL recognized

Warranty:

Units are warranted against defects in materials and workmanship for a period of one year from date of delivery. See warranty information for specific details.



HT431 Dimensions

