



Expert Advice. Great Value. Contact Us Today!

Call: 203-647-9147 **Email:** sales@haywardts.com

Website: www.haywardts.com

**SecureTurn HT431
Standard Passage**

**Full height for maximum security.
Heavy-duty construction lasts a lifetime.**

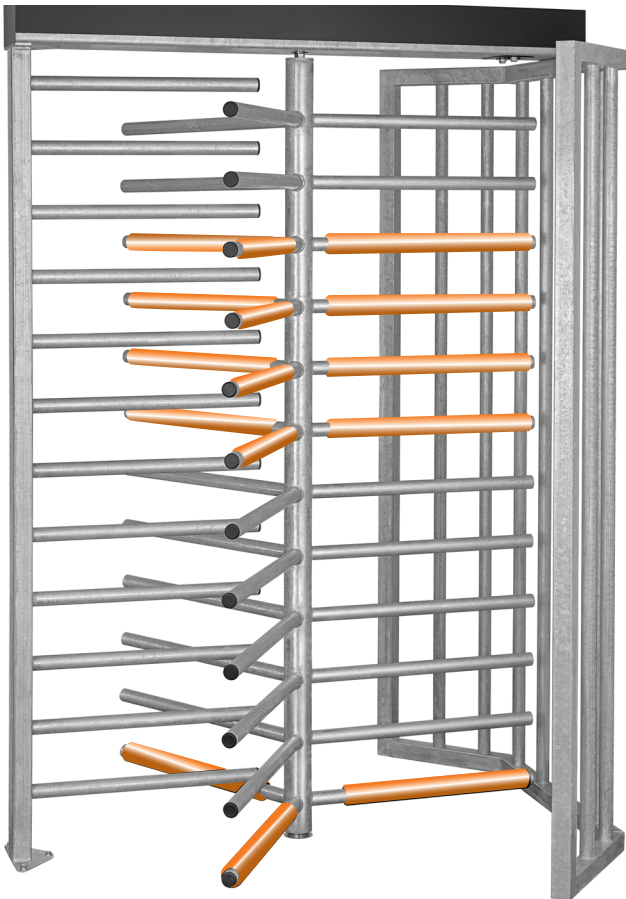

SecureTurn HT431 Standard Passage

Shown with optional Safety Sleeve Bulk Pack (15 sleeves).

Color choice of Safety Orange or Steel Gray.

Applications:

The SecureTurn HT431 standard passage full height turnstiles are designed and engineered to meet all your security and access control requirements. Wherever control of pedestrian traffic is necessary, these full height turnstiles will perform flawlessly. Used as either stand alone units or as part of a fully integrated security control package, these quality turnstiles will fit your needs and your budget.

Materials and finishes available in:

- Hot Dip Galvanized Steel
- Powder Coat over Steel
- 304 Stainless Steel

Padded Safety Sleeves helps prevent accidents and enhance turnstile usability (optional):

Avoids injuries – Reduces bruising – Stops heel slams
Softens impacts – Easy-grab cushion grip
Cool to the touch in heat – Insulates bars in cold

Other single passage models in this series:

- SecureTurn HT439 Wide Passage 39"
- SecureTurn HT448 Extra Wide Passage 48"

Double passage models in this series:

SecureTurn HT430T tandem size for standard passage consists of (2) SecureTurn HT431 in a space saving layout.

About Hayward Turnstiles:

Hayward Turnstiles has over 50 years of expertise in quality manufacturing of precision aircraft parts and reliable turnstiles.

Our factory, in Milford, CT, is AS9100 Certified to aerospace standards resulting in superior turnstiles. Engineered to industrial grade specifications, they are durable and built tough for long lasting performance. Proudly made in the USA, we distribute worldwide with installations across the globe.

Get in touch with us for expert advice, design assistance, project review, free quotes and for help with your security needs.

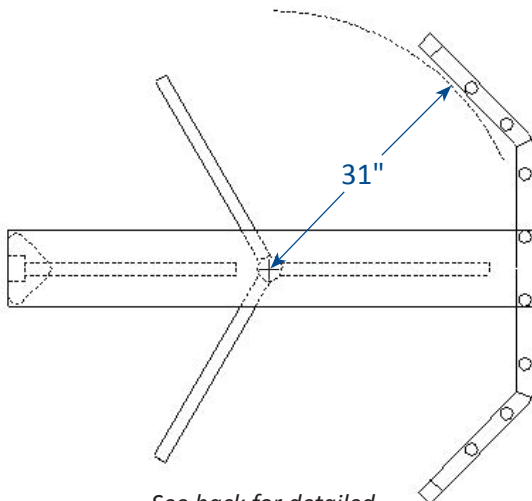

See back for detailed dimensions and specifications.

***SAFETY SLEEVE SAVINGS BONUS**

Your choice of with any full height turnstile order:

- Heel Pack (3 sleeves) - \$149.95 (**Save \$149.95**)...now **FREE*** or
 - Bulk Pack (15 sleeves) - \$749.95 (**Save 33%**)...now **\$499.95*** or
 - Total Pack (36 sleeves) - \$1,799.95 (**Save 33%**)...now **\$1,199.95***
- Additional sleeves \$49.95 each...Call 203-647-9154 for details.

HT431 Specifications

Applications:

The SecureTurn HT431 standard passage full height turnstiles are designed and engineered to meet all your security and access control requirements. Wherever control of pedestrian traffic is necessary, these full height turnstiles will perform flawlessly. Used as either stand alone units or as part of a fully integrated security control package, these quality turnstiles will fit your needs and your budget.

Product Features:

Materials and finishes in your choice of:

- Hot dipped galvanized steel
- Powder Coat over steel
- 304 Stainless Steel

Design & Construction:

- Designed for secure operations with aesthetics in mind
- Choice of right or left handed direction
- Fully welded exterior components
- Heavy-duty lifetime construction

Turnstile Operation:

- Self centering mechanism with hydraulic shock suppression
- Permanently lubricated bearings
- Clockwise, counter clockwise, or bidirectional passage

Options:

- Electronic locking module featuring heavy-duty 24 VDC solenoids and card reader interface
- Fail-Safe (*free passage on power failure*)
- Fail-Lock (*locked passage on power failure*)
- Interfaces with card readers, biometrics, wireless remotes, push button, metal detectors, etc...
- Card reader mounting plates
- Electronic six digit resettable counter with LCD display and ten-year lithium battery
- Manual key override (*both directions*)
- Red/Green indicator lights
- Safety Sleeves (*Safety Orange or Steel Gray*)
- Additional options available upon request

Electrical Specifications:

Power supply input 100-240VAC (.7 amp) 50/60hz output 24VDC (1.1 amp) All components UL recognized

Warranty:

Units are warranted against defects in materials and workmanship for a period of one year from date of delivery. See warranty information for specific details.



HT431 Dimensions

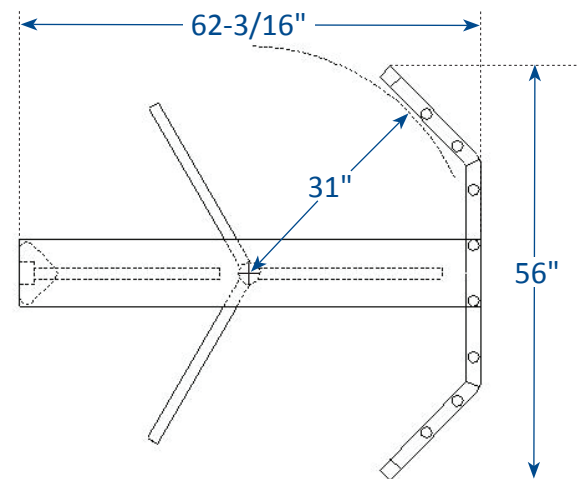
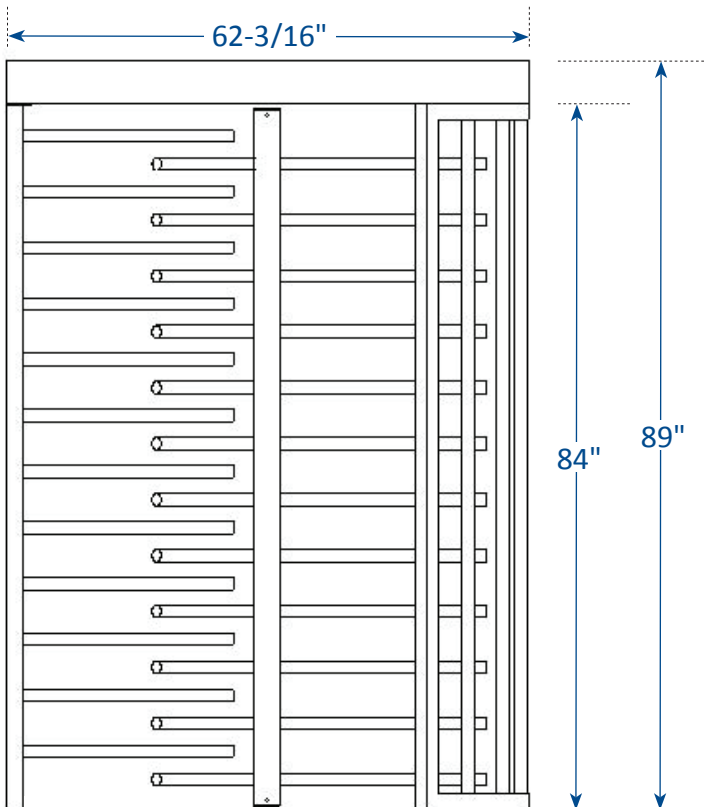

Expert Advice. Great Value. Contact Us Today!

Call: 203-647-9147 Email: sales@haywardts.com

Website: www.haywardts.com

HAYWARD TURNSTILES, INC.
160 Wampus Lane, Milford CT 06460

FREE*
Safety
Sleeves

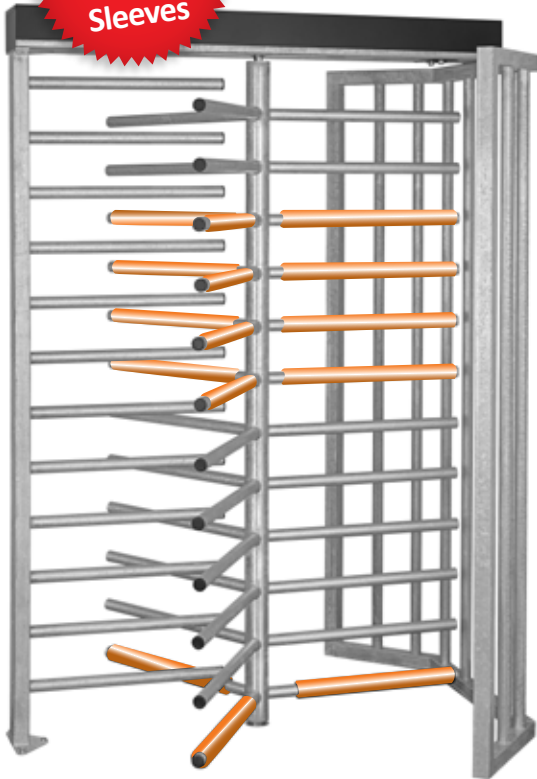

Padded Safety Sleeves for turnstiles helps prevent accidents & enhances usability.

- Avoids injuries
- Reduces bruising
- Stops heel slams
- Softens impact
- Face saver
- Easy-grab cushioned grip
- Cool to the touch in extreme heat
- Insulates bars in severe cold
- Safety Orange for visible alert
- Steel Gray for discrete look



Non-covered bars are round tubular steel.

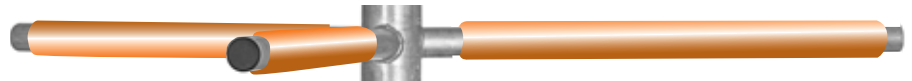

Covered bars with padded safety sleeves add protection and comfort.

Indoor/Outdoor Use — Weatherproof & Long Lasting — Compliments Appearance



Installs and quickly zips closed in seconds.



Fits tight and prevents spin.



Soft-touch exterior pushes easily
Note: Install zipper face down.



Note: Sleeve cut to show padded foam interior.

Specifications:

- Exterior fabric is industrial grade PVC material
- Interior foam is laminated to PVC and tear-resistant
- Heavy-duty trimmed sewn edges on all four sides
- Measures 23" long with full-length resin zipper
- Color choice of Steel Gray or Safety Orange
- Ships flat ready for quick install.

HAYWARD TURNSTILES, INC.

Safety Sleeve color choices complement your turnstiles appearance.

Steel Gray for discrete look.



Safety Orange for visible awareness.

Safety Sleeve packs helps you choose your level of protection.

BASIC PROTECTION
Heel Pack (3)

STANDARD PROTECTION
Bulk Pack (15)

MAXIMUM PROTECTION *(suggested)*
Total Pack (36)



(shown in Safety Orange)

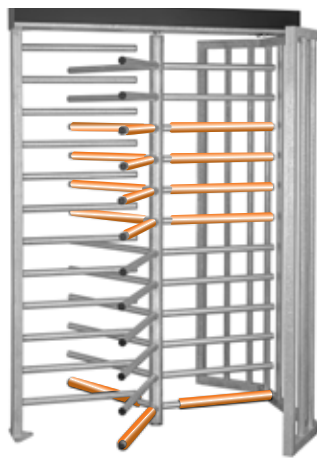

(shown in Safety Orange)

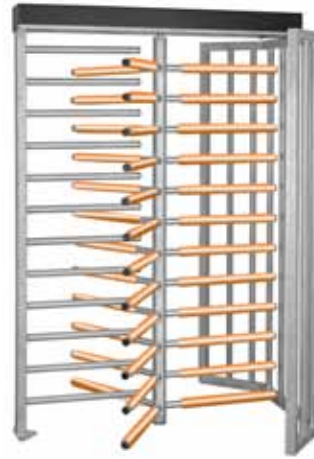

(shown in Safety Orange)



(shown in combo pack Safety Orange & Steel Gray)

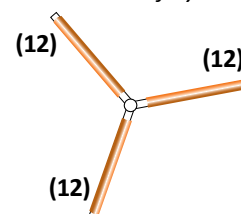
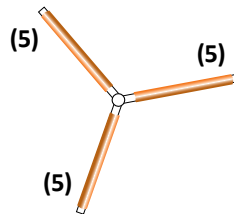
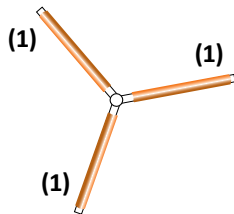

Heel Pack (3 sleeves)
\$149.95 *(Save \$149.95)*
FREE

or

Bulk Pack (15 sleeves)
\$749.95 *(Save \$250)*
Sale Price \$499.95...**Save 33%**

or

Total Pack (36 sleeves)
\$1,799.95 *(Save \$600)* **Sale**
Price \$1,199.95...**Save 33%**



***Special savings bonus. Your choice with any full height turnstile order.**
Additional sleeves \$49.95 each.
Call 203-647-9154 for bonus details.



Expert Advice. Great Value. Contact Us Today!
Call: 203-647-9154 Email: sales@haywardts.com
Website: www.haywardts.com





Date: _____

ORDERED BY:

SHIP TO: SAME AS ORDERED BY

Name: _____

Name: _____

Address 1: _____

Address 1: _____

Address 2: _____

Address 2: _____

City: _____ St: _____ Zip: _____

City: _____ St: _____ Zip: _____

Phone: _____ Cell: _____

Phone: _____ Cell: _____

Email: _____

Email: _____

****Special Savings Bonus. Your choice with any full height turnstile order:***

| QTY | ITEM | COLOR/AMOUNT | PRICE | SALE PRICE | TOTAL |
|-----|--|--|--------------------------|------------|-------|
| | Heel Pack (3 sleeves) Free | <input type="checkbox"/> Gray _____ (pcs.) <input type="checkbox"/> Orange _____ (pcs.) | \$149.95 (Save \$149.95) | FREE | |
| | Bulk Pack (15 sleeves) Save 33% | <input type="checkbox"/> Gray _____ (pcs.) <input type="checkbox"/> Orange _____ (pcs.) | \$749.95 (Save \$250) | \$499.95 | |
| | Total Pack (36 sleeves) Save 33% | <input type="checkbox"/> Gray _____ (pcs.) <input type="checkbox"/> Orange _____ (pcs.) | \$1,799.95 (Save \$600) | \$1,199.95 | |

Additional sleeves \$49.95 each.

ORDERING INFORMATION:

(Payment required with order)

Mail to: Hayward Turnstiles
 160 Wampus Lane
 Milford CT 06460

Phone: 203-647-9154

Fax: 203-200-7886

Email: sales@haywardts.com

SHIPPING & HANDLING

| # of Sleeves | Amount |
|--------------|--------|
| 0-39 | FREE |
| 40-99 | FREE |
| 100 or > | FREE |

| | |
|------------------------------|------|
| Sub-Total | |
| Shipping/Handling | FREE |
| Sub-Total | |
| *CT Sales Tax (6.35%) | |
| Total | |

**For businesses located in CT.*

Payment Information: Check MasterCard Visa Amex

Name on Card: _____

Card #: _____

Signature: _____

Expires: _____ Security Code: _____